

Assembly Instructions - Lancelot® and Squire®

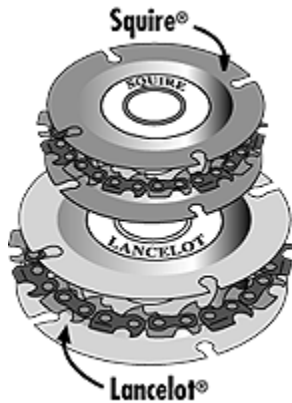

King Arthur's Tools (KAT) is pleased to present the first tandem mounted saw chain accessories whereby differing combinations of Lancelot and Squire may be paired together on the same disc grinder. Our products cut with saw chain teeth and can be dangerous if not used properly.

It is important to read these instructions carefully before proceeding further. You will be rewarded with an increased knowledge that allows you to safely enjoy the use of our products and increase your productivity.

DO NOT OPERATE LANCELOT OR SQUIRE WITHOUT FIRST ADJUSTING THE SAFETY GUARD. (See Below)

Lancelot and Squire are efficient, versatile and highly maneuverable tools designed for the rapid removal of all kinds of materials – including wood, ice, plastic, pvc, and rubber. Though primarily designed for the cutting, removal and sculpting of wood, Lancelot and Squire, whether used singularly or in combination can be used in a multitude of applications. Some of these include: notching, stump removal, construction, log homes, drum making, free form bowl carving and ice carving.

Individual & Combination Usage Precautions

1. When used individually, Lancelot and Squire fit most 4" (100mm), 4-1/2" (115mm) and for the European market only, 125mm disc/angle grinders. Models are available in M14 (14mm), 5/8" (16mm) or 7/8" (22mm) arbor sizes. See Diagram 1 for model sizes.
2. Under no circumstances can tandem mounted KAT accessories be used on 4" (100mm) grinders. When used in a tandem combination, Lancelot can be matched with another Lancelot or Squire blade but only on 4-1/2" (115mm) or European market 125mm disc grinders with M14 (14mm) or 5/8" (16mm) threaded shafts. They can be paired with the same or different tooth configuration, e.g. Lancelot: 22 tooth and 22 tooth (22/22), 22/14, 14/14; Lancelot & Squire: 22/18, 22/12, 14/18, 14/12.
3. The best tandem combination is to match two KAT accessories with M14 (14mm) or 5/8" (16mm) center holes and the KAT Universal Nut which must be used when using this dual blade combination. As an added feature, the Universal Nut is specially designed to easily and safely tighten any other 5/8" (16mm) arbor accessories on your disc grinder.
4. The only other combination is to seat a Lancelot M14 (14mm) or 5/8" (16mm) blade on the bottom of the threaded shaft with a 7/8" (22mm) on top, using manufacturer's flanged 7/8" (22mm) lock nut to secure both blades.

WARNING: FAILURE TO OBSERVE ALL SAFETY RULES, INSTRUCTIONS AND PRECAUTIONS MAY RESULT IN SERIOUS INJURY TO USER OR OTHERS.

INSTRUCTIONS FOR USE

- Recommended for use with disc/angle grinders equipped with constant pressure switch (paddle, dead man or kill switch.)
- Unplug power source from grinder when assembling, cleaning, sharpening or removing the tool. Grinder switch must be OFF before connecting power.
- It is **EXTREMELY IMPORTANT** the safety guard is **RESET** to the '**CORRECT**' position as detailed in these instructions. **DO NOT REMOVE SAFETY GUARD OR AUXILIARY HANDLE.**
- Always ensure work piece is securely held in a vice. Do not grip or support the work piece with hands, feet or other body parts.
- Leather or chain saw or kevlar lined gloves and footwear are highly recommended.
- At all times, both hands must be used to operate the grinder.
- Always use safety glasses and/or a full face visor during operation.
- Inspect and remove all nails, staples and wire obstructions from lumber before cutting.
- Never start the grinder when the blades are in contact with stock material.
- Never put the grinder down until it has stopped completely. Failure to do so could cause the grinder to 'walk', causing injury or damage. Similarly, do not ram the blades into wood to stop them turning prematurely once the power switch is turned off.
- Regularly clean the disc grinder's on/off switch and remove wood shavings and dust. Accumulated debris around and under the switch could clog the mechanism, making it hazardous in operation.
- Only operate Lancelot and Squire at a safe distance from others.
- Let the cutting tools do the work. They are fully capable. Do not force tools into the work or apply excessive pressure.
- Keep hands away from Lancelot and Squire's blades during operation. Do not reach underneath work or attempt to remove material while blades are rotating.
- Keep blades clean and sharp using a 5/32" (4mm) saw chain file.
- Read these instructions in conjunction with the disc grinder owner's manual for additional user instructions and safety rules.

GENERAL SETUP

Remove any non-KAT accessory from the disc grinder. Adjust the safety guard as shown on WARNING - SAFETY GUARD and assemble Lancelot or Squire as instructed in CHAIN AND DISC ASSEMBLY.

CHAIN AND DISC ASSEMBLY - Lancelot and Squire

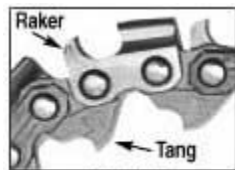

DIAGRAM 2

LANCELOT MODEL SIZES (See tool decal)	
41414	- M14 (14mm) arbor, 14 teeth
41422	- M14 (14mm) arbor, 22 teeth
45814	- 5/8" (16mm) arbor, 14 teeth
45822	- 5/8" (16mm) arbor, 22 teeth
47814	- 7/8" (22mm) arbor, 14 teeth
47822	- 7/8" (22mm) arbor, 22 teeth
2 CHAIN SIZES: 40014 - 14 teeth (wide cuts, rapid removal)	
40022 - 22 teeth (quick, clean cuts; finer finish)	
SQUIRE MODEL SIZES	
31412	- M14 (14mm) arbor, 12 teeth
31418	- M14 (14mm) arbor, 18 teeth
35812	- 5/8" (16mm) arbor, 12 teeth
35818	- 5/8" (16mm) arbor, 18 teeth
37812	- 7/8" (22mm) arbor, 12 teeth
37818	- 7/8" (22mm) arbor, 18 teeth
2 CHAIN SIZES: 30012 - 12 teeth (wide cuts, rapid removal)	
30018 - 18 teeth (quick, clean cuts; finer finish)	

Diagram 1 shows the assembly of the Squire and Lancelot discs onto a grinder. The Squire disc is on top, and the Lancelot disc is on the bottom. Arrows indicate the direction of assembly. The Squire disc has 'SQUIRE' and 'LANCELOT' stamped on it, and the Lancelot disc has 'LANCELOT' stamped on it.

DIAGRAM 1

1. Remove plastic center fastener. Retain for assembly when not attached to grinder.
2. Place BOTTOM disc on even surface, with the stamped word BOTTOM and directional arrow facing up.
3. Place chain on BOTTOM disc with number 25 or 72 stamped on tang facing down. Ensure chain link tangs fit over disc perimeter, with rakers facing left. SEE DIAGRAM 2. If assembled in reverse, saw chain blades will not cut efficiently and will appear blunt

during operation by burning the wood.

4. Place TOP disc over chain circlet, with the decal and the side stamped TOP side facing up. Minor adjustment will secure chain between the two plates. SEE DIAGRAM 1. Lancelot or Squire is ready for mounting to disc grinder.

KAT Universal Nut

IMPORTANT: You must use the respective Universal Nut whenever tightening Lancelot/ Lancelot or Lancelot/ Squire tandem combinations with M14 (14mm) or 5/8"(16mm) centers.

The Universal Nut has a 13/16" (21mm) hexagonal head with a flat base which secures pressure evenly over the blades and allows ample locking threads to safely and securely tighten a dual combination.

Available in either M14 or 5/8" 11, standard shaft sizes on most major manufacturers disc grinders.

Simply tighten with a 13/16" (21mm) spanner, socket, spark plug socket or adjustable wrench. It's much easier and safer than the traditional two pin spanner wrench.

Using Lancelot or Squire 7/8" (22mm) Blades As A Single Accessory

After GENERAL SETUP, place Lancelot or Squire, TOP side up, over threaded shaft until seated over 7/8" (22mm) arbor of manufacturer's adaptor. Tighten securely with manufacturer's lock nut.

Using Lancelot or Squire M14 (14mm) or 5/8" (16mm) Blades As A Single Accessory

When using either of the above sizes, insure the grinder's threaded shaft diameter matches the blade center hole diameter. It is generally recommended that the manufacturer's backing plate/adaptor is removed so that blade sits on the bottom flange of threaded shaft. There should be ample and sufficient distance and clearance for safe operation where the cutting teeth and the safety guard come closest. This method is especially recommended for grinders with oversize backing discs that will cause an interference to the depth of cut. Tighten securely with manufacturer's lock nut. If, however, blades touch safety guard, replace the manufacturer's backing plate, remount blade to sit on arbor and retighten. There must be 1) no movement or slippage of the saw chain between discs and 2) discs and chain must rotate as one unit.

TANDEM MOUNTING

Two Lancelots or Lancelot/ Squire on M14 (14mm) or 5/8" 11 threaded shafts

1. REMOVE THE GRINDER BACKING PLATE - Manufacturers supply a flanged backing plate or adaptor to accommodate 7/8" (22mm) accessories on all disc grinders. When mounting two blades, both with the same centers, either M14 (14mm) or with 5/8" (16mm), remove this backing plate. If plate is not removed, there are insufficient threads on the threaded shaft for the universal nut to lock down this tandem combination. After removing plate, first mount one Lancelot (NOT Squire) over the threaded shaft followed by the second Lancelot OR Squire. The bottom disc of the top mounted Lancelot or Squire sits on the top disc of the first Lancelot and is tightened with the Universal Nut. You must use and tighten the Universal Nut with a 13/16" (21mm) spanner or socket, spark plug or adjustable wrench to secure this combination. Tighten until one thread or less is left visible on the nut. There must be 1) no movement or slippage of the saw chains between discs and 2) discs and chains must rotate as one unit. SEE DIAGRAM 3.

TANDEM MOUNTING

One Lancelot With M14 (14mm) or 5/8" (16mm) Center and One Lancelot or Squire with 7/8" (22mm) Center

1. DO NOT ATTEMPT TO TANDEM MOUNT A 7/8" (22mm) LANCELOT ON THE BOTTOM OF THREADED SHAFT WITH AN M14 (14mm) OR A 5/8" (16mm) LANCELOT OR SQUIRE ON TOP.
2. REMOVE THE GRINDER BACKING PLATE.
3. TIGHTEN WITH MANUFACTURER'S LOCK NUT.

DIAGRAMS 3 and 4

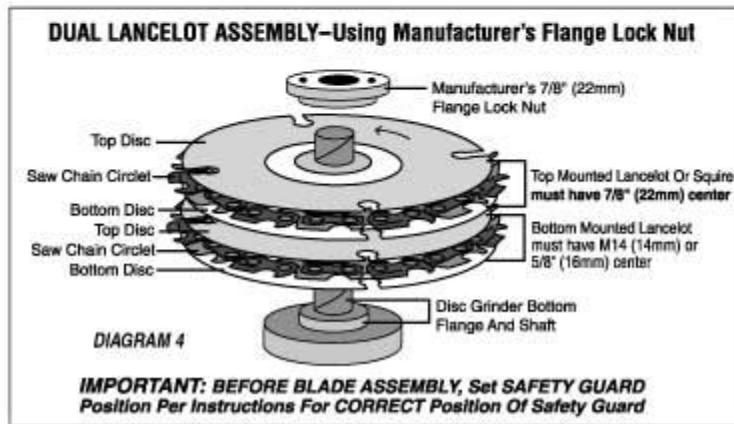
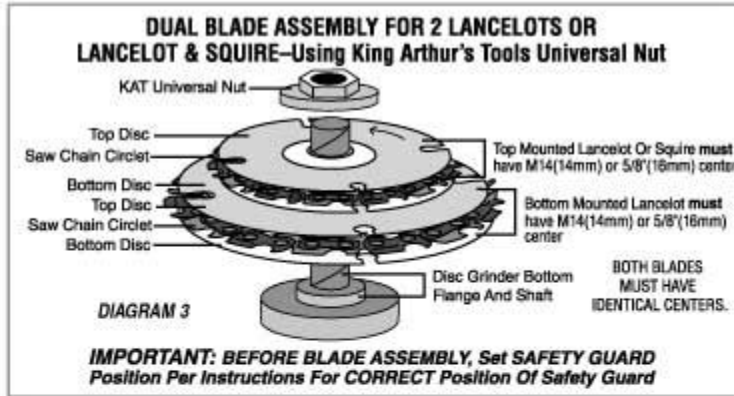

These instructions are generally the same as tandem mounting a dual combination with M14 (14mm) or 5/8" (16mm) centers with the following important exceptions. After removing the grinder backing plate, first mount one Lancelet (NOT Squire) with a M14 (14mm) or 5/8" (16mm) center over the threaded shaft followed by the second Lancelet or Squire with a 7/8" (22mm) center. Any minor play prior to tightening the nut should be eliminated when this combination is secured.

You must use the manufacturer's Flanged Lock Nut. Insert the flange face down into the center hole of the top mounted Lancelet or Squire and tighten securely using manufacturer's spanner wrenches. As a guide, the top of the nut will be level or below the top of the threaded shaft when secured. There must be 1) no movement or slippage of the saw chains between discs and 2) discs and chains must rotate as one unit. SEE DIAGRAM 4.

WARNING: SAFETY GUARD

UNDER NO CIRCUMSTANCES SHOULD LANCELOT OR SQUIRE BE OPERATED UNLESS THE POSITION OF THE SAFETY GUARD HAS FIRST BEEN ADJUSTED AS INSTRUCTED.

The angle of adjustment for the safety guard varies with each disc grinder manufacturer. THE MAIN CRITERIA IS THAT THE BOTTOM OF THE SAFETY GUARD MUST BE AS LEVEL AS POSSIBLE WITH THE BOTTOM OF THE BODY OF THE DISC GRINDER. In this position, the SAFETY GUARD WILL ADJUST BETWEEN THE (APPROXIMATE) ANGLES OF 23 degrees and 45 degrees .

DO NOT REMOVE SAFETY GUARD

ADJUST THE SAFETY GUARD 23 degrees TO 45 degrees – LEVEL WITH THE BOTTOM OF THE DISC GRINDER–SEE OPERATING INSTRUCTIONS. LANCELOT AND SQUIRE ARE DESIGNED TO CUT WITH THE GUARD ADJUSTMENT SET 23 degrees TO 45 degrees .

WITHOUT THE GUARD RESET, THESE CUTTERS WILL NOT CUT PROPERLY AND POSE A DANGER TO THE USER.

Main reasons for this requirement:

1.Safe and efficient operation: Lancelot and Squire were designed to cut, shape, carve etc. with their bottom and partially exposed left side cutting edges. Lancelot and Squire cut on their periphery (cutting edge), different than a traditional grinding wheel or sanding attachment which operates on its side (or face). With the guard rotated to the position stated in these instructions, it opens up the bottom surface of these cutting heads near the bottom of the grinder. This is where a considerable amount of the main cutting is done and is: A) a vital part of its versatility B) allows for optimum cutting utilization in a comfortable and safe position. 2. Direction of Waste: With the safety guard properly adjusted, direction of wood chips and shavings will be angularly deflected over the top of Lancelot and Squire, hitting the top of the work piece and away from the operator's hands and face. If the guard is retained at 90 degrees, wood waste is directed upwards toward the hands/face.



Do NOT use Lancelot or Squire on any Makita brand grinders. We only recommend use of 4-1/2" (115mm) angle grinders with a **constant pressure switch (paddle, kill or dead man switch).**

DANGERS of not adjusting SAFETY GUARD

Without the guard reset, it is very difficult and dangerous to complete even the simplest of cuts and no cutting operation must be attempted. Operating the grinder at 90 degrees forces the user to constantly operate the grinder in an awkward and unsafe manner for which these accessories were not designed.

Method of Adjustment: Grinders may have two or three adjustable screws (generally Phillips) or a single screw "clamp" securing the safety guard. As a guide to this procedure, lay the grinder face up, remove the lock nut(s) and backing plate, loosen screws, turn the safety guard toward the left and upwards until the bottom of the guard is level with (or as close to) the bottom of the disc grinder and retighten. Refer CORRECT Diagram.

If you have difficulty adjusting the safety guard, please call King Arthur's Tools at 1-800-942-1300 1-800-942-1300 for further information.

DO NOT OPERATE LANCELOT OR SQUIRE WITHOUT FIRST ADJUSTING THE SAFETY GUARD.